

# 1 Materials Engineering

## Polymer Processing and Thermoforming

**Reference:** Principles of Polymer Engineering, by N. G. McCrum, C. P. Buckley and C. B. Bucknall, Oxford University Press.

---

### 2 EXTRUSION

- 60% of global output of all commodity plastics.
- Endless product of constant cross-section that is subsequently reduced to a portable length.
- Extruder converts solid feedstock into a homogeneous melt and pumps it through a die at a uniform rate.

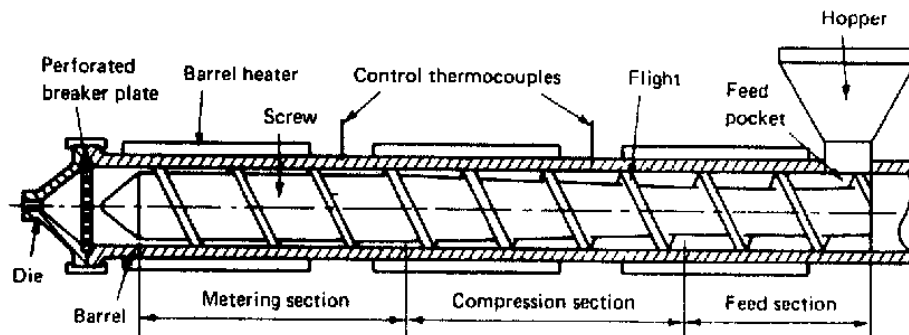

---

### 3 Extruder Barrel

- Must be v. strong to withstand high pressure applied by liquid polymer.
  - Size of extruder is defined by internal diameter (2.5 - 15 cm) and length to diameter ratio ( $L/D = 5 - 34$ ).
  - Short machines ( $L/D \leq 20$ ) used to process elastomers; long machines for thermoplastics.
  - $L/D$  is measure of capability of screw to mix and melt materials and of amount of energy required to run extruder ( $L/D$  high ? mix, melt and energy high)
  - Most common feed to barrel is by gravity.
  - Point of entry into barrel is cooled by circulating water to avoid pellets heating in hopper (could weld into a mass and block flow).
  - Working of the plastic by the screw generates additional heat, which can be large enough for extrusion to continue even if heaters were switched off. Thus, need to add/extract heat from barrel.
-

## 4 Extruder Screw

Transports solid feedstock. Compresses and melts the solid. Homogenises melt and generates sufficient pressure to pump the melt against resistance of the die.

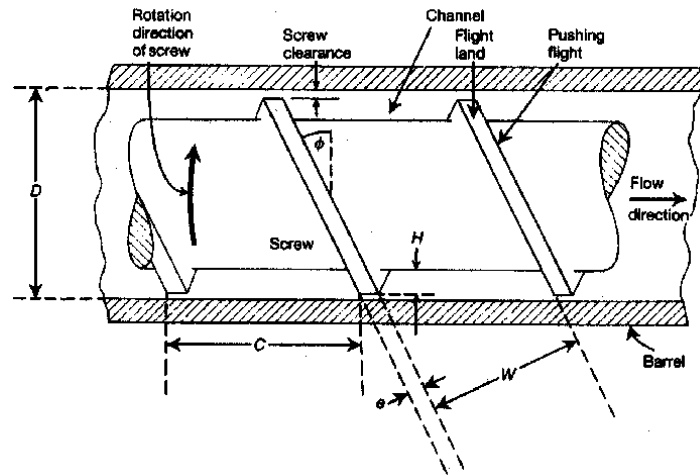

## 5 Extruder Screw

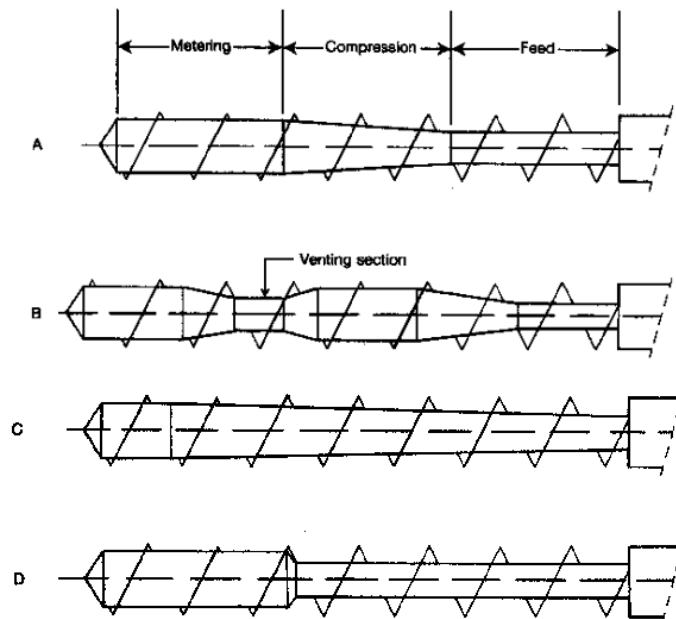

A 3-zone screw with feed section of constant flight depth, compression and metering sections. Geometry and position of compression section matches the melting and softening characteristics of a particular polymer.

B 3-zone screw with vented section (exhaust out gases from melt; pressure drops) via vacuum line or hole drilled in barrel wall.

C 'PVC' type screw for amorphous polymers which progressively soften through the  $T_g$ .

D 'Nylon' type screw for crystalline polymers with sharp  $T_g$ .

## 5.1 Extruder Die

This is the shaping tool mounted on end of extruder.

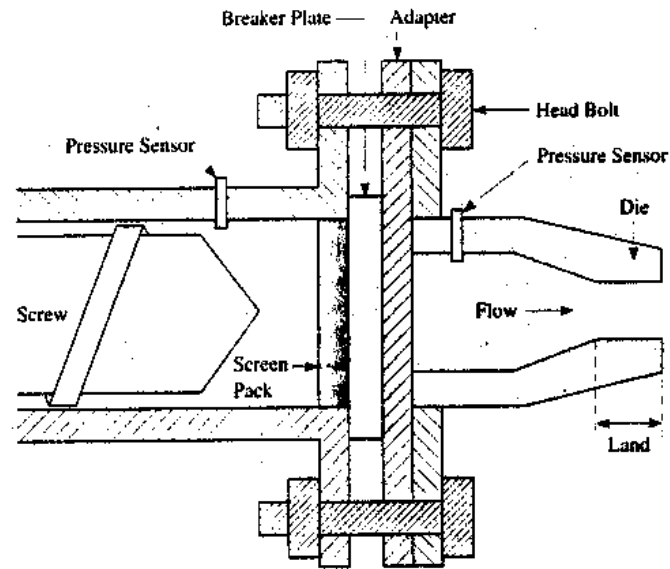

## 5.2 Extruder Die

Die shape must allow for changes in part cross-section because of flow differences between restricted and non-restricted parts of the die:

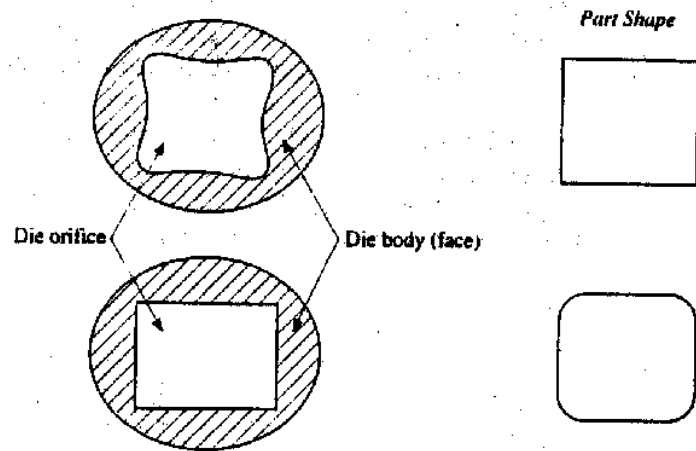

## 5.3 Extruder Die

Can extrude a hollow part by forcing molten polymer into a cylindrical shape using a mandrel:

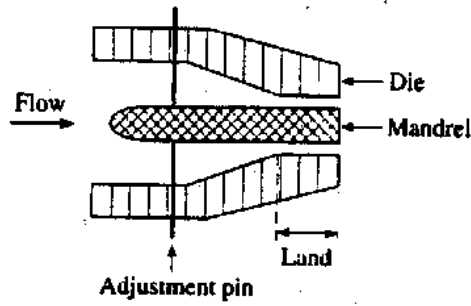

(a) Spider die

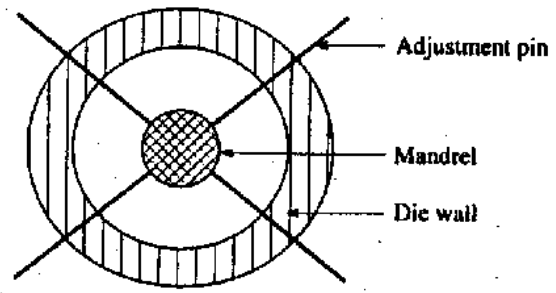

(b) Spider die-rear view

## 6 Lab Demonstration

Lab equipment is very different to industrial process.

- Polymer (Polystyrene) placed in metal cylinder
- Polymer melted in oven
- Cylinder is placed underneath pneumatic ram
- Ram forces melt through die. Extrudate cools in water
- There is considerable expansion of the extruded material once it exits the die

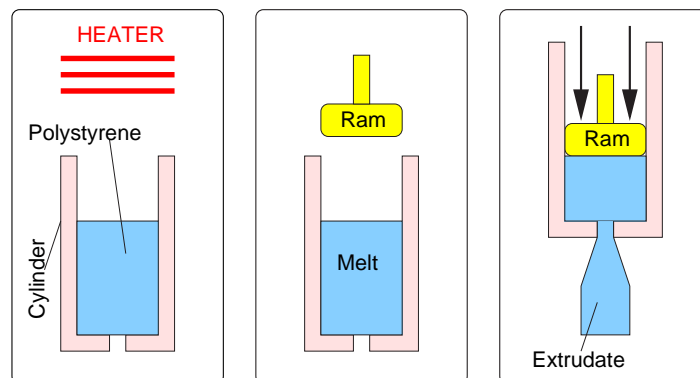

Single biggest difference is that the laboratory demonstration is not a continuous process. Most industrial extrusion is a continuous process, producing great lengths of uniform cross section (which can then be chopped up into lengths required for specific applications).

## 7 Injection Moulding

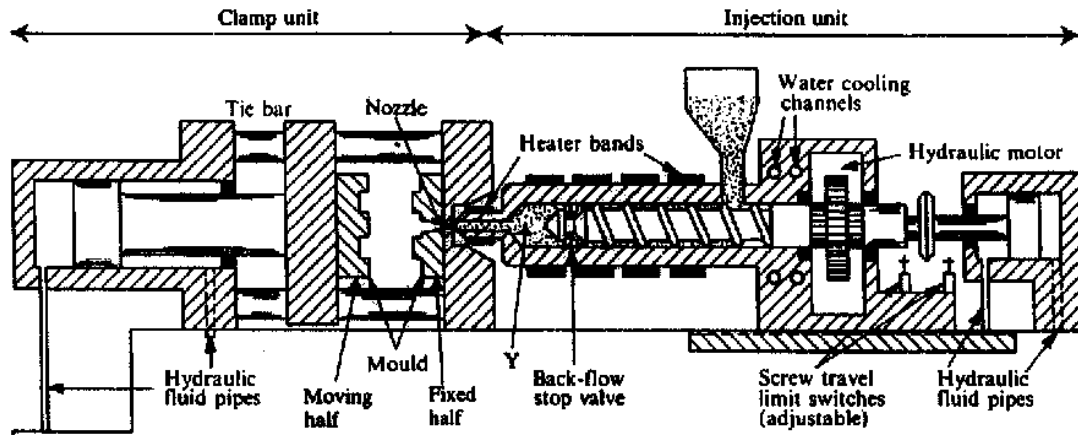

## 8 Reciprocating screw IM machine

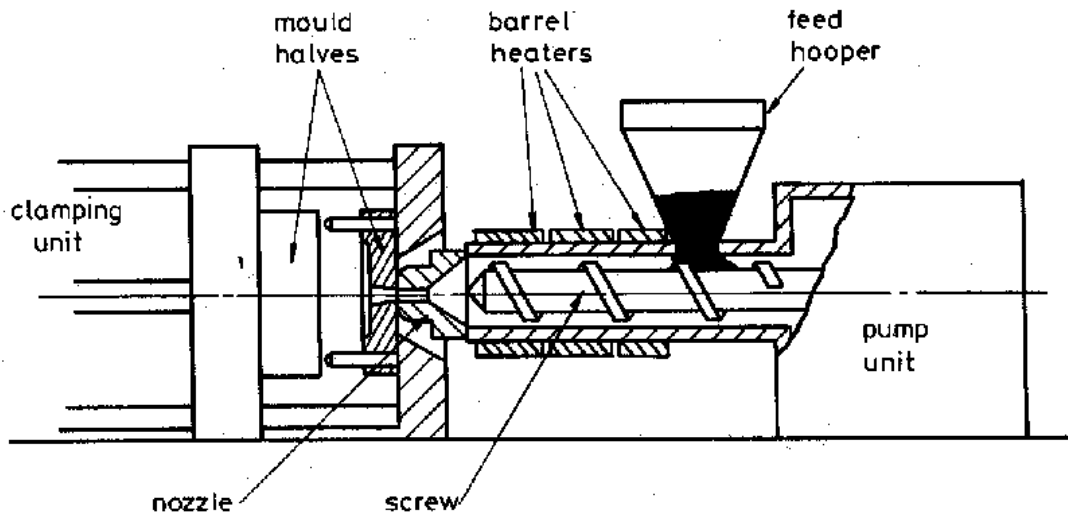

## 9 Injection Moulding Procedure

Cyclical process:

1. Mould closes.
2. Screw moves along barrel acting like a plunger (without rotation) and forces a quantity of plasticised material into mould.
3. Screw remains forward, maintaining pressure, while material in mould begins to cool and set.
4. When mould material solidifies, the screw starts to rotate and move backwards, drawing new material from hopper, and feeding this to front of screw. When sufficient material has been plasticised for next shot, a limit switch stops screw from rotating.
5. When moulding has had time to set, mould opens to eject part. The mould then closes and cycle is repeated.

## 9.1 Single Impression Mould

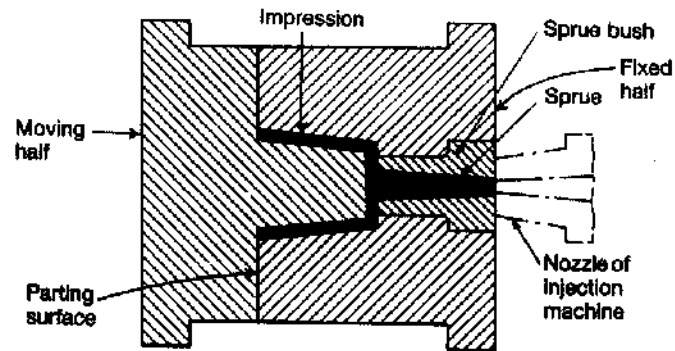

## 9.2 Multiple Impression Mould

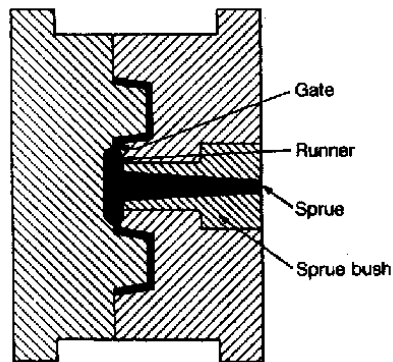

---

## 10 Feeder System

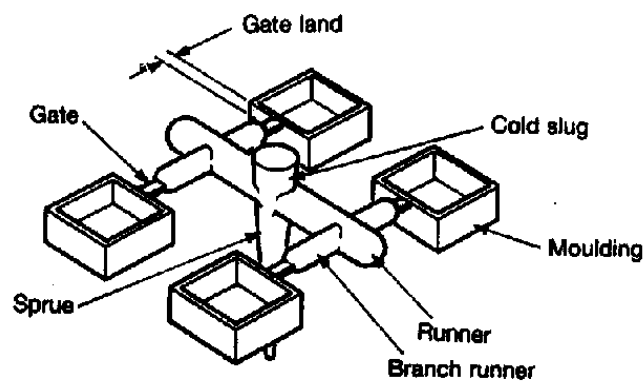

---

## 11 Gate

- Causes work to be done when liquid is forced through constriction. Viscosity goes down  $\Rightarrow$  helps mould filling.
- Controls rate of liquid flow into cavity.
- Once frozen mechanically insulates mould from liquid in the barrel

- Many gate cross-sections possible

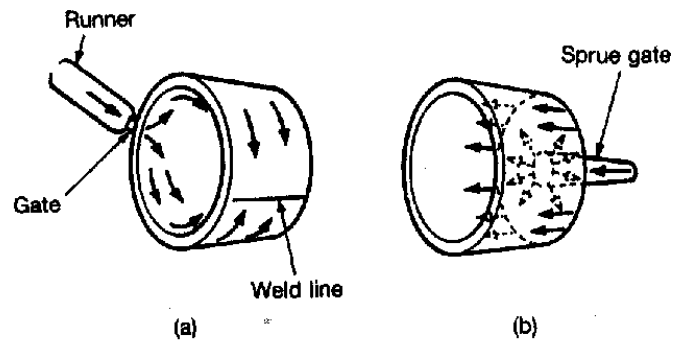

## 12 Lab Demonstration

In this case the lab demonstration is relatively similar to the industrial process.

- Polymer (Polyethylene) placed in metal cylinder
- Polymer melted in oven
- Cylinder is placed underneath pneumatic ram, and mould below cylinder nozzle
- Ram forces melt into mould.
- Once cooled, the moulding is removed from the mould.

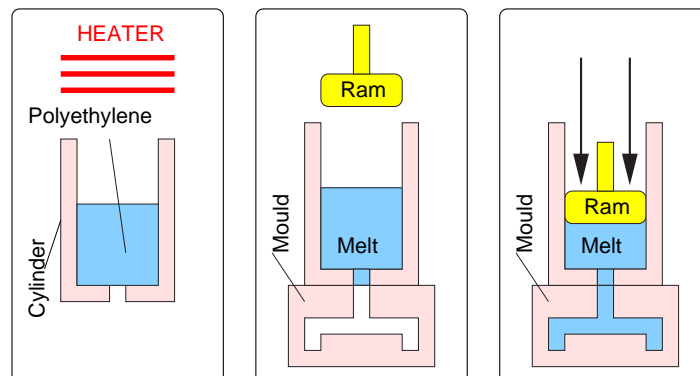

## 13 Vacuum Forming

Dates back to 1950s.

Relatively simple technique:

1. Thermoplastic sheet is clamped over a negative mould
2. Sheet is softened by heating
3. Vacuum is drawn within mould through vents
4. Sheet is drawn into contact with mould and allowed to cool

Once the sheet is cooled it can be removed from the mould.

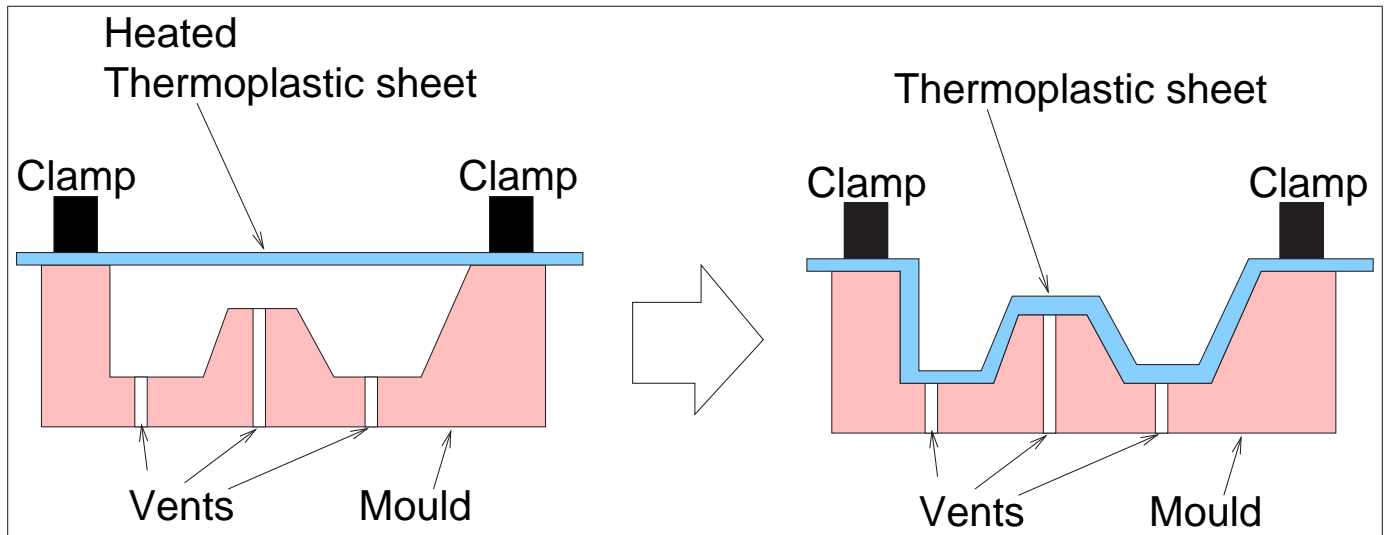

## 14 Vacuum Forming

Disadvantages:

- Wall thickness varies
- Need to do a lot of finishing work  $\Rightarrow$  waste (time and material)
- Polymer is heated twice (once to make sheet, second time to mould sheet)
- Limited range of shapes available
- Detail not great due to low pressure differential

However, the process is not without its uses...

Advantages/Applications:

- Technique is simple and has low capital cost
- Suitable for large formings
- Widely used for thin walled packaging (e.g. for sandwiches, electronics, blister-packs).
- Useful for short-runs or prototypes

## 15 Vacuum Forming

This is potentially a **very** simple technique, and can be implemented at little cost, even by hobbyists:

<http://www.studiocreations.com/stormtrooper/main.shtml>



---

## 16 Vacuum Forming

### 16.1 Some notes

- Tool/mould can be negative or positive (see previous slides). Negative gives good external detail, positive give good internal detail.
  - Tool can be made of wood, metal, plaster or epoxy.
  - Vacuum gives pressure differential of about 1 atm. Can add positive pressure on other side for total differential of up to 10 atm. Better output but costs increase.
  - Sheet material needs to have reasonable form stability when heated  $\Rightarrow$  needs to have a fairly high relative molecular mass. E.g. Polystyrene, Acrylics, PVC, Polypropylene
  - *Pre-stretch* can be employed to give better distribution of material in wall and to produce deeper formings. E.g. Vacuum bubble snap back technique.
- 

## 17 Lab Demonstration

Pretty typical vacuum forming operation

- Sheet of polystyrene is clamped in place
- Heater softens the sheet of polystyrene
- After about 10 minutes ready to vac-form

- Mould pushed up into sheet, and vacuum drawn at same time
- Note how much trimming would be required to finish the component

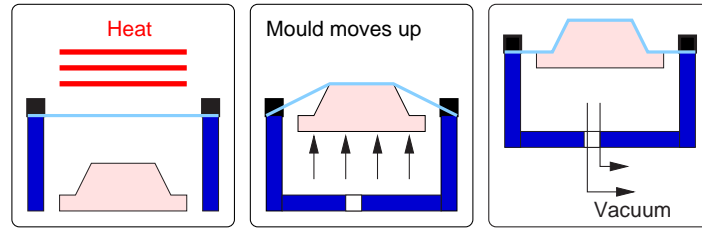

## 18 Fluidised Bed

Used to put a coating onto metal components.

- Part to be coated is heated in oven
- Air is circulated through nylon powder, *fluidising* it.
- The heated component is dipped into the powder and a coating of nylon melts and sticks to it.

## 19 Dome Blowing

Physical properties at least as interesting as the process.

- Sheet of cast acrylic is heated in the oven until soft
- Acrylic is removed from oven and clamped over dome-blowing rig
- Air is pumped in from below, causing soft acrylic to form a “bubble” or dome
- Once acrylic has hardened, air pressure is removed and the sheet can be taken from the clamp.
- Once sheet is reheated, it relaxes and returns to its original shape and can be re-blown.