

1 3rd Year Engineering Materials

Viscoelasticity – Lecture 3

2 Viscoelastic Behaviour

2.1 Typical Creep and Recovery

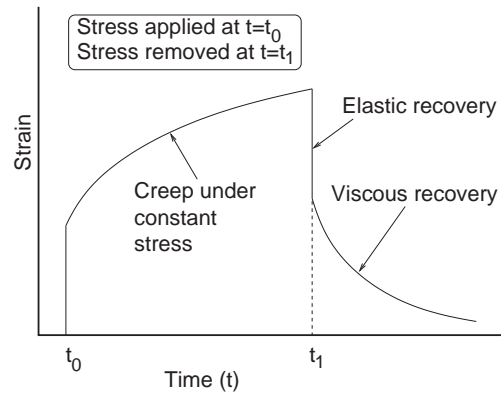

3 Viscoelastic Behaviour

3.1 Creep and Recovery Models

We can attempt to model the behaviour of a viscoelastic material using simple mechanical elements:

- Springs
- Dashpots/Dampers

3.2 Springs

- Stress in spring:

$$\sigma = k\epsilon \quad k \text{ is the stiffness of the spring}$$

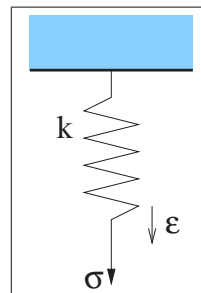

- Stress is purely a function of the instantaneous strain.
-

4 Viscoelastic Models

4.1 Dampers

- Strain depends on stress history, not just on stress at a moment in time.
- Stress in dashpot/damper:

$$\sigma = \mu \frac{d\epsilon}{dt} = \mu \dot{\epsilon}$$

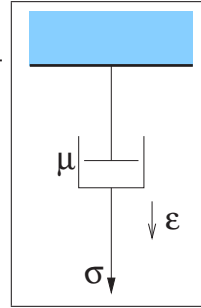

5 Viscoelastic Models

5.1 Available Models

- Spring reminds us of the elasticity behaviour of a viscoelastic material
- Damper reminds us of the viscous behaviour (e.g. creep)
- Combination of spring(s) and damper(s) might give a good model
- Three models will be examined here:
 - Kelvin Model
 - Maxwell Model
 - Standard Linear Solid
- Look at each in turn

6 Viscoelastic Models

6.1 Kelvin Model

- Kelvin Model is composed of a spring and a damper in **Parallel**
- Stress and Strain are connected as:

$$\begin{aligned}\sigma &= \sigma_1 + \sigma_2 \\ \epsilon &= \epsilon_1 = \epsilon_2\end{aligned}$$

- So the Governing Equation is

$$\sigma = k\epsilon + \mu\dot{\epsilon}$$

- We can use this to predict the behaviour of the material...

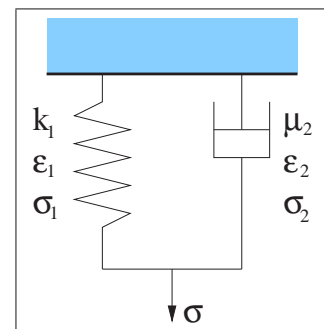

7 Viscoelastic Models

7.1 Kelvin Model

- Handles Creep fairly well
- Handles Recovery fairly well
- Does not account for relaxation

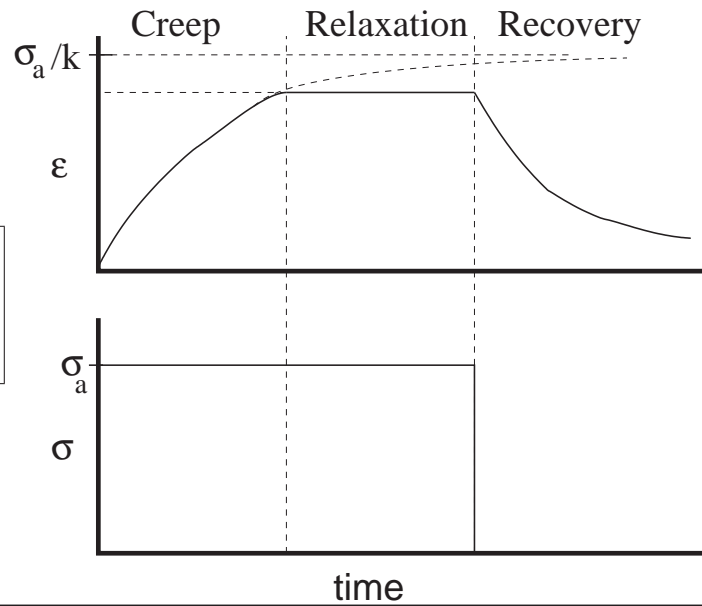

8 Viscoelastic Models

8.1 Maxwell Model

- Maxwell Model is composed of a spring and a damper in **Series**
- Stress and Strain are connected as:

$$\sigma = \sigma_1 = \sigma_2$$

$$\epsilon = \epsilon_1 + \epsilon_2$$

- So the Governing Equation is

$$\dot{\epsilon} = \frac{\sigma}{\mu} + \frac{\dot{\sigma}}{k}$$

- We can use this to predict the behaviour of the material...

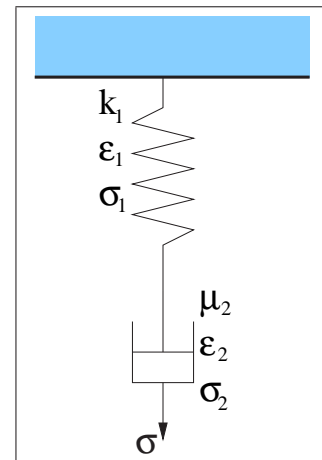

9 Viscoelastic Models

9.1 Maxwell Model

- Handles Creep badly (model creeps without bound at constant rate)
- Handles Recovery badly (model only recovers elastic deformation, and does so instantly)
- Accounts fairly well for Relaxation

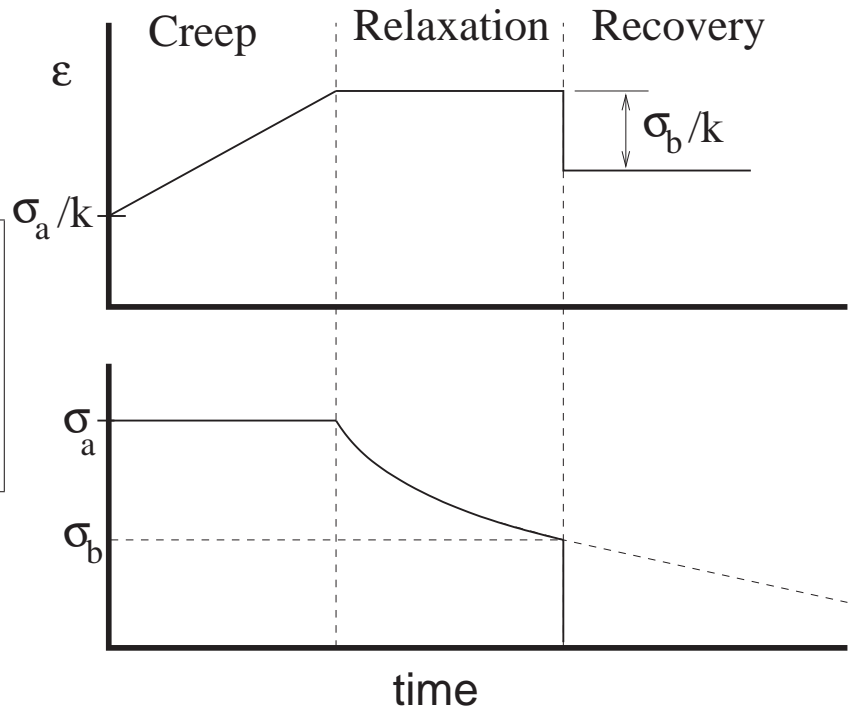

10 Viscoelastic Models

10.1 Standard Linear Solid Model

- Also known as the Zener Model
- Can represent in a couple of ways
 - Spring in Series with a Kelvin model
 - Spring in Parallel with a Maxwell model

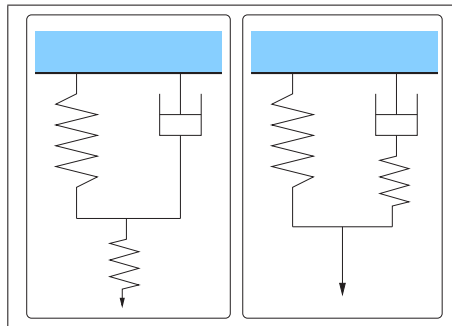

11 Viscoelastic Models

11.1 Standard Linear Solid Model

- Exhibits the following behaviour:
 - Instantaneous elastic strain when stress applied
 - Under constant stress, strain creeps towards a limit
 - Under constant strain, stress relaxes towards a limit
 - When stress is removed, instantaneous elastic recover, followed by gradual recovery towards zero strain.
 - Two time-constants:
 - * One for creep/recovery under constant stress
 - * One for relaxation under constant strain

12 Viscoelastic Models

12.1 Standard Linear Solid Model

