1 3rd Year Engineering Materials

Polymers – Lecture 2

2 Commodity Polymers

2.1 Four main commercial polymers

- PE (polyethylene)
 - PP (polypropylene)
 - PVC (polyvinyl chloride)
 - PS (polystyrene)
-

3 Polyethylene

Simplest of all is polyethelene

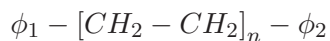

- $n \approx 10^4$; ($10^3 \leq n \leq 10^4$)
 - Endgroups ϕ_1 and ϕ_2 occur in tiny concentration and do not affect mechanical properties much
 - Endgroups **do** affect chemical stability
 - Mechanical properties affected by
 - Chain length (relative molecular mass)
 - Shape of molecule (e.g. sidebranches)
-

4 Addition Polymerisation

4.1 Polyethylene (PE) (C_2H_4)

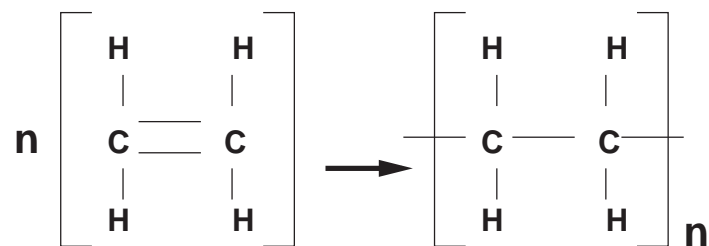

- Introduce monomer (C=C) into reaction vessel
- Inject initiator to mix with monomer (these form free radicals, e.g. peroxide, which get things started).

- One of the outer electrons in the C=C bond interacts with a free radical (initiation step).
- Remaining C=C electron then acts as a free radical and interacts with another C=C monomer (propagation step)
- Process continues as long as fresh monomer is available. Chain length of thousands of monomers.

5 Addition Polymerisation

Termination of the chain happens when there is interaction of two carbon free-radicals, or through interaction with another electron rich molecule (contaminant/quench)

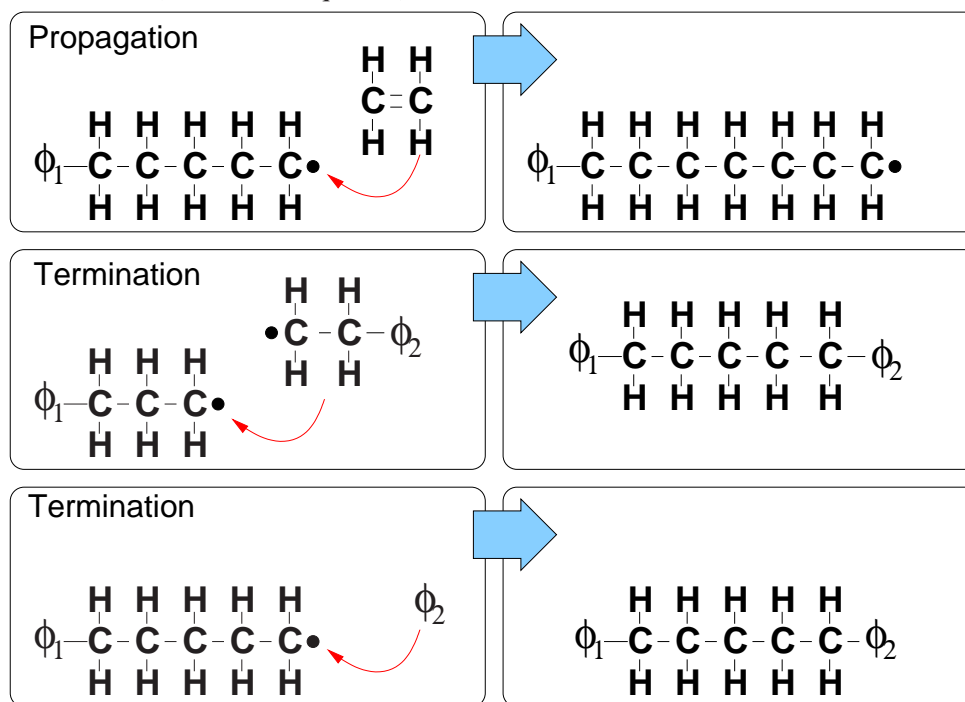

6 Addition Polymerisation

6.1 Backbiting/Side-Branched

Backbiting leads to side-branches as shown below

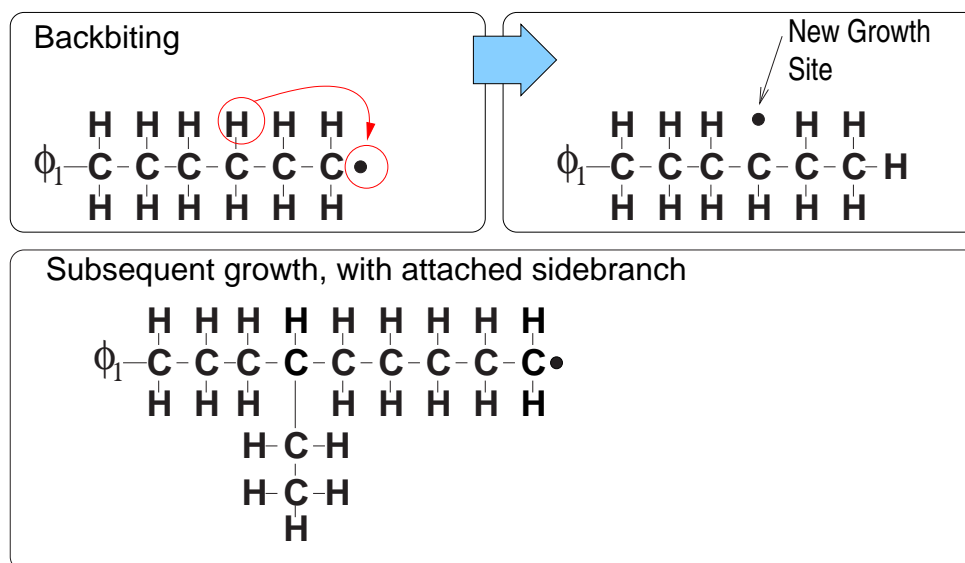

The free radical at the end cannibalises a hydrogen atom from further back in the chain, leaving a free radical there. This new free radical becomes the point of subsequent growth.

7 Addition Polymerisation

7.1 Vinyl Polymers

These polymers are similar to polyethylene. They are of the following form:

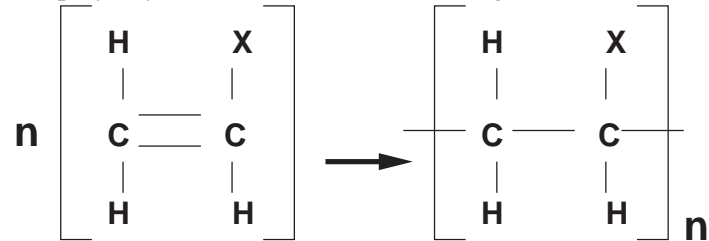

Where X can have various forms...

8 Addition Polymerisation

8.1 Polypropylene (PP) (C_2H_3X), $X = CH_3$

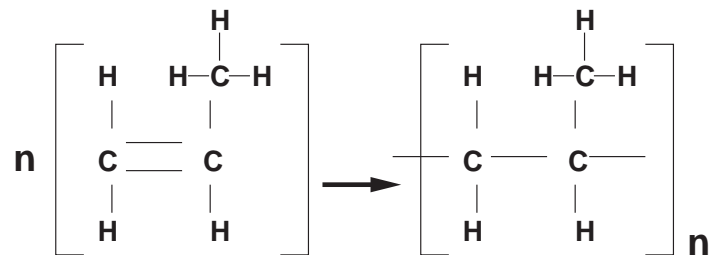

PP is a high-volume, low-cost plastic. Used in moulding, extrusion, film and fibre processes. Good water resistance, and used widely in pipes and in many automotive applications.

8.2 Polyvinyl chloride (PVC) (C_2H_3X), $X = Cl$

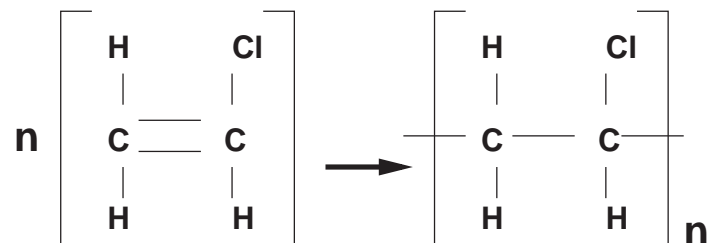

PVC is low-cost, high-volume. In plasticized state (mixed with low molecular weight liquid to soften it) it is used for hoses, clothing, wire and cable insulation, floor-coverings. uPVC is unplasticized, and this stiffer form is used in building materials (e.g. window frames, plumbing).

9 Addition Polymerisation

9.1 Polystyrene (PS) (C_2H_3X), $X = C_6H_5$

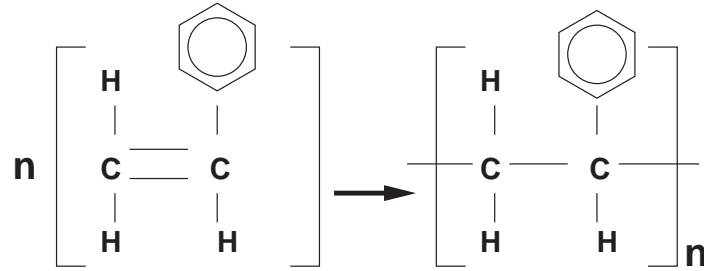

Low-cost, high-volume. Used widely in packaging and kitchenware, and when expanded is used as thermal insulation.

9.2 Polytetrafluoroethylene (PTFE) (C_2F_4)

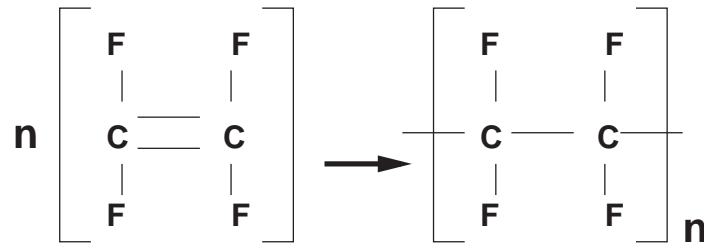

High melting point $327^\circ C$, and very low coefficient of friction. Used in corrosive circumstances in chemical plant (e.g. gaskets, tubing, taps, etc.) and in demanding electrical applications.

10 Addition Polymerisation

10.1 Polymethylmethacrylate (PMMA)

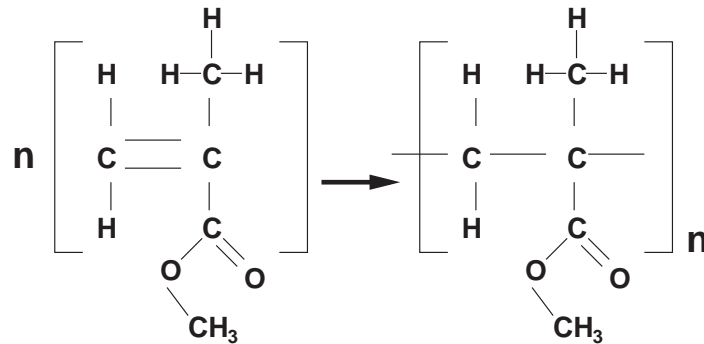

Perspex. An acrylic resin. Medium-cost, medium-volume. Used in glazing and in illuminated outdoor signs.

11 Condensation Polymerisation

- e.g. Nylon/Polyamide
 - Two monomers combine chemically.
 - A by-product molecule is formed.
 - Each monomer molecule must have 2 reactive functional groups in order for the reaction to be sustainable
-

12 Condensation Polymerisation

12.1 Polyamide/Nylon

Hexamethylene diamine + adipic acid

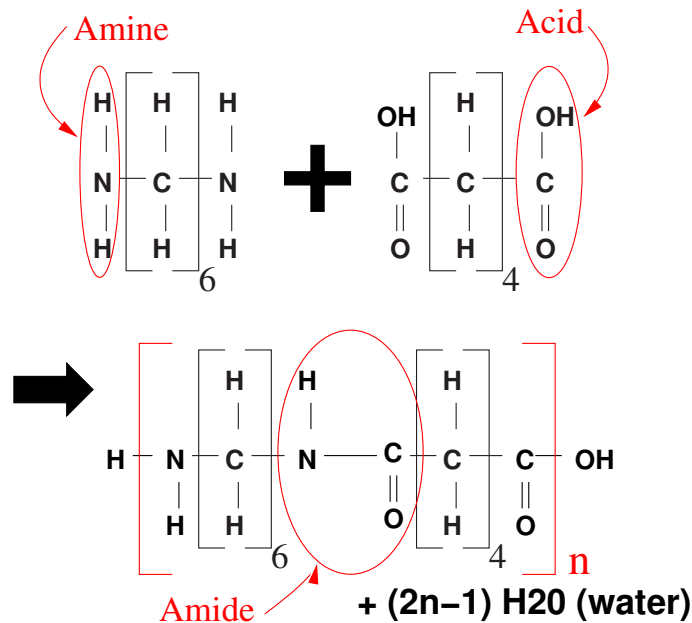

Nylon is the most widely used engineering thermoplastic and is especially useful when used in fibre-form. Good mechanical properties (tough, strong, abrasion resistant). Often used as matrix for composite materials. Presence of the NH and CO groups leads to water absorption, causing reduction in stiffness and expansion.

13 Condensation Polymerisation

13.1 Reaction Sequence

- Monomers *A* and *B* (bot with 2 active sites) are heated & agitated
 - One end of *A* reacts with one end of *B*, forming a bond linking *A* and *B*. By-product (e.g. water) formed.
 - New molecule is start of polymer chain, and has active functional groups on each end. One end can react with an *A*, while the other end can react with a *B*.
 - Chains can react with each other too
 - Chain growth stops when chain length is so long that reactive sites cannot interact.
 - Reaction can be quenched by adding material with a single active end (allows some control of molecule length).
-

14 Condensation Polymerisation

14.1 PolyEthyleneTerephthalate (PET)

Terephthalic acid + ethylene glycol

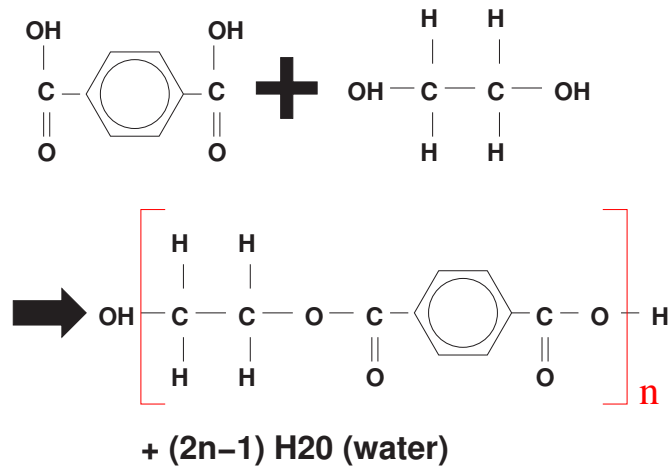

PET is used as a fibre, and also as an engineering thermoplastic. One of the family of thermoplastic polyesters, used in switch components, housing, bearings and bottles.

15 Condensation Polymerisation

- In every case, we get a regular pattern of



where *A* and *B* are the two monomers involved

- This regularity encourages crystal formation
-

16 Copolymers

- Polymers composed of two or more different monomers
 - e.g. if Ethylene and Propylene are polymerised simultaneously
 - The minority component modifies the properties of the majority
 - Similar concept to metal alloys
 - Can be useful for improving thermal stability... e.g. POM
-

17 Cross-Linked Polymers

- We have looked at monomers with functionality of 2
 - Each monomer reacts with two others
 - This gives linear molecular structure
 - Functionality 4 monomers exist also
 - Such monomers can link the polymer chains
-

18 Cross-Linked Polymers

- Say *A* has functionality 2, and *B* has functionality 4
- A small amount of *B* can be copolymerised with *A* to give a cross-linked structure

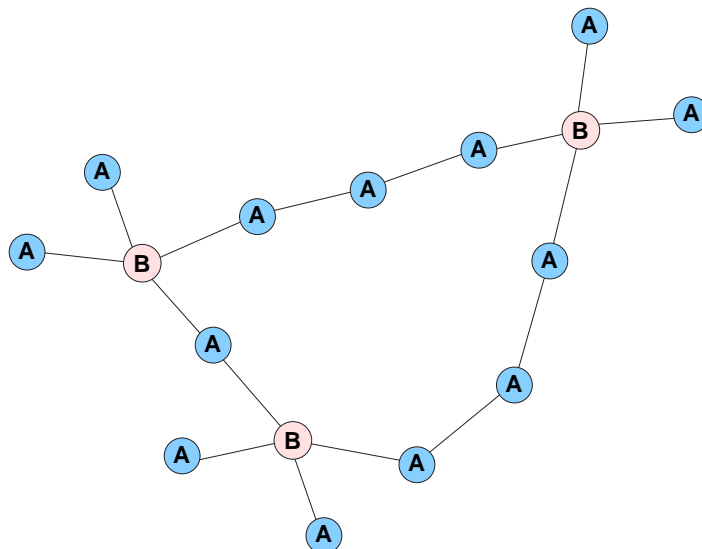

19 Cross-Linked Polymers

19.1 Divinyl Benzene

An example of such a monomer with a functionality of 4 is divinyl-benzene

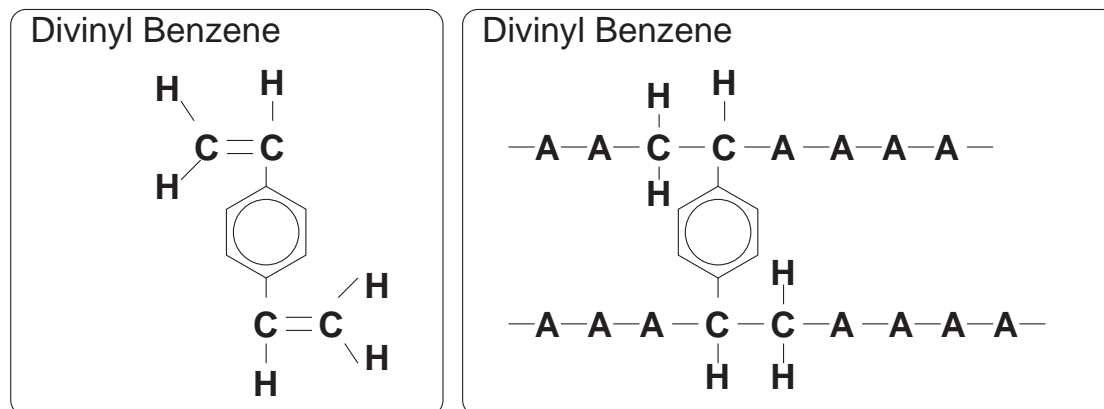

There are two double carbon-to-carbon bonds. Each can open up, allowing bonding with 2 monomers per bond, to make for a total of 4.

You can also cross-link already formed polymer (e.g. using β - or γ -rays on polyethylene).

Cross-linked polymers retain shape memory even after being heated.