1 2nd Year Civil Engineering

NDT – Lecture 2

2 Embedded Defects

- Internal to a component
 - Do not break surface of defect
 - However, they may be associated with surface damage, e.g. impact
 - Difficult to detect visually
 - Difficult to detect as they grow
 - Can lead to catastrophic failure
-

3 Embedded Defects

3.1 Destructive Testing

- Strength test may indicate presence of internal defect
- Fatigue test may reveal presence of (initially) microscopic internal defects

Weaknesses in this approach

- Can only get information about a statistical sample of parts
 - To get information about in-service parts, need to retire a sample for destruction
 - No guarantees with regard to untested parts (i.e. all parts in service)
-

4 Embedded Defects

4.1 Nondestructive Testing

- Need ways to “look inside” solid material
 - Two commonly used techniques are available
 - Radiography
 - Ultrasound
 - Both have applications in medicine and in these roles are familiar to most lay people.
-

5 Radiography

5.1 Basic Principles

- X-Rays pass through matter that is opaque to many other wavelengths of electromagnetic radiation
 - As X-Rays pass through matter, they become absorbed.
 - The greater the thickness, the greater the level of absorption
 - Some materials absorb more than others (metal versus flesh)
 - Higher atomic number and density gives higher absorption
 - Though X-Rays are invisible, they cause photographic film to expose
 - Photographic film can be used to measure the amount of radiation passing through a body, and from the resulting image we can get information on the internal structure/composition of the body.
-

6 Radiography

6.1 Basic Principles

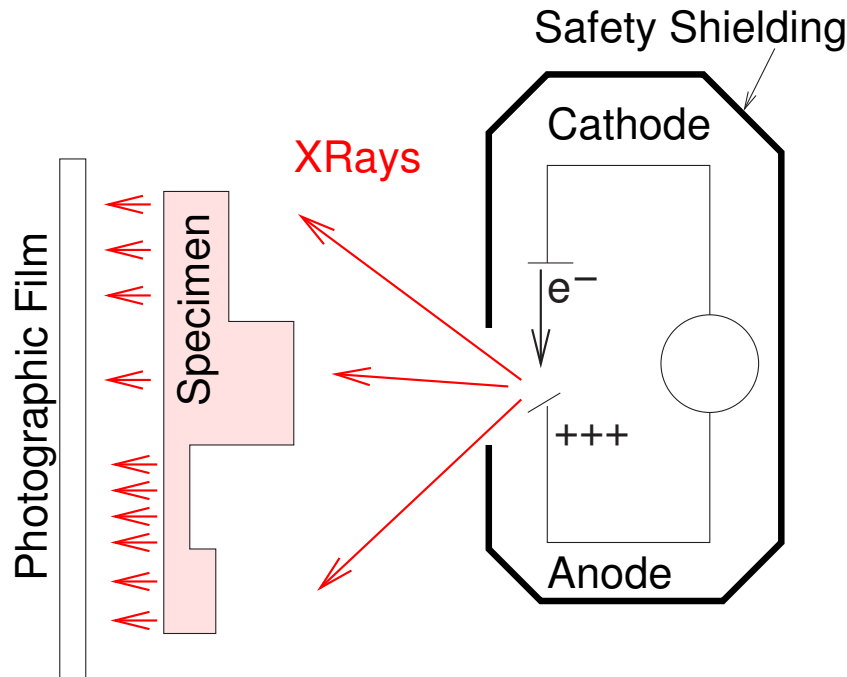

Note that the film and specimen should be closer together than shown in this diagram.

7 Radiography

7.1 Basic Principles

- Electrons are emitted from a tungsten filament cathode
- A high voltage accelerates them towards the tungsten anode
- Electrons in atoms of anode are excited to higher energy states
- As they return to original states, they give off energy in form of X-Rays.

7.2 Absorption

- I_0 is incident intensity
- μ is linear absorption coefficient
- t is thickness

$$I = I_0 \exp(-\mu t)$$

8 Radiography

8.1 Basic Principles

- As film is exposed, it goes from white (transparent) to black opaque (when later developed).
 - Black areas correspond to places where more X-Rays get through
 - Light areas/shadows are regions of increased thickness/density, for example
 - Inclusion of some denser material
 - Variation in cross-section
 - Dark areas are regions of decreased density/thickness, for example
 - Voids
 - Cracks
-

9 Radiography

9.1 Factors Affecting XRay Sensitivity and Definition

- Fine-grained film emulsion
 - Low X-Ray Energy or long wavelength (“softer” X-Rays)
 - Low accelerating voltage
 - Long tube to film distance
 - Thin metal samples
 - Large difference in relative absorption coefficients of material and discontinuity (e.g. steel versus air)
 - Having discontinuities/defects near the film
-

10 Radiography

10.1 Aids

- Intensifier
 - Intensifier is like a sheet of paper placed on the photographic film
 - It contains material which glows when illuminated with X-Rays
 - This glow further exposes the film and can improve the resulting image quality
-

11 Radiography

11.1 Aids

- Image Quality Indicator (IQI)
 - Helps to indicate what thickness of defect can be found
 - Many designs, simplest is a set of wires of different thicknesses made from same material as test-piece
 - Included in X-Ray
 - Thinnest wire visible in X-Ray indicates minimum resolveable change in thickness

11.2 Defect Sizing

- Finding length/area of defect is fairly straightforward
- Thickness can be estimated (IQI)
 - Volume can be estimated

12 Radiography

12.1 Defect Orientation

- Depending on defect geometry, its orientation can be very important in determining its detectability
- Volume defects (e.g. porosity, cavity) equally easy (or hard) to see from all directions
- Cracks can be very difficult to see in some directions

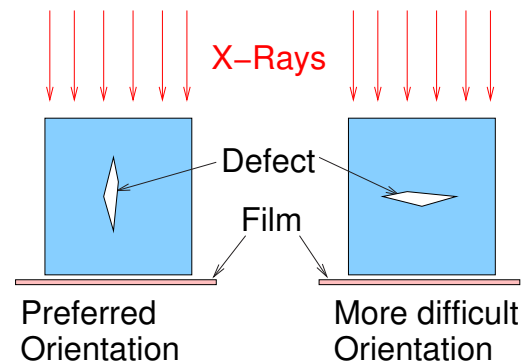

13 Radiography

13.1 Gamma Rays

- X-Ray machines are generally large and heavy
- For field-tests (e.g. chemical plant pipework) a gamma ray source is more convenient
 - Source is a Radioisotope (radioactive material)
 - Source is portable, requires no power
 - Radioisotope cannot be “turned off”: always dangerous
 - X-Ray machine only dangerous when activated

13.2 Safety

- For gamma rays and X-Rays, exposure of living tissue to the radiation must be avoided and minimised. Chronic exposure can cause cancer and death. Extreme acute exposure can kill more quickly.

14 Ultrasound

14.1 Basic Concepts

- Similar to Sonar or Radar
 - Sound waves are propagated into the test-piece
 - Waves interact with defects and boundaries
 - Reflect
 - Attenuate (i.e. not propagate)
 - From observation of interaction, information can be gained on internal defects and flaws.
-

15 Ultrasound

15.1 Pulse-Echo

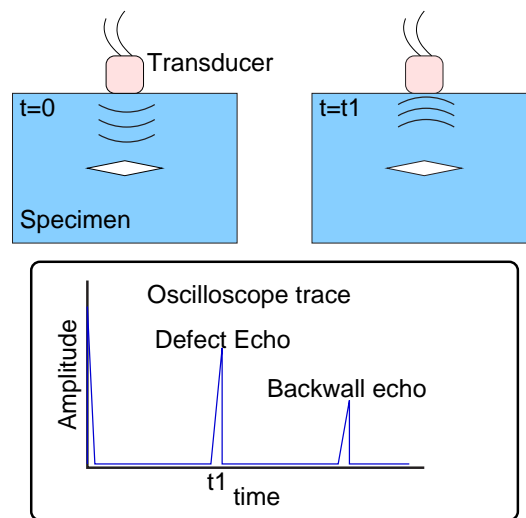

Timing of Reflection gives indication of defect depth

16 Ultrasound

16.1 Pitch-Catch/Through-Transmission

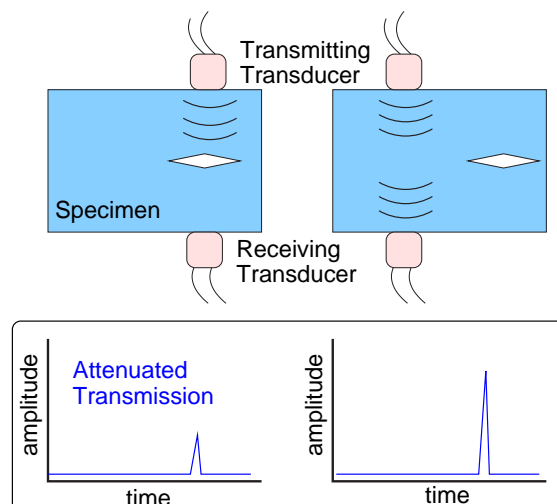

17 Ultrasound

17.1 Defect Orientation

- As for radiography, depending on defect geometry, its orientation can be very important in determining its detectability
- Cracks can be very difficult to see unless they are perpendicular to the propagating waves

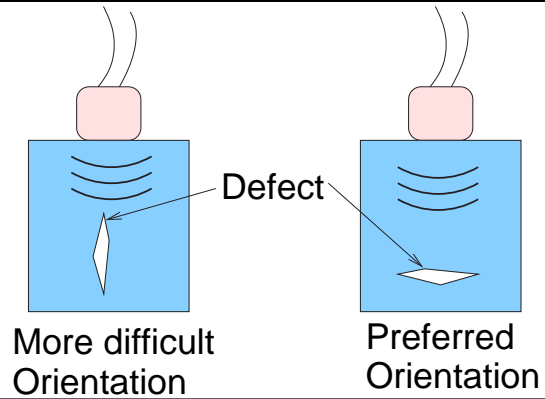

18 Ultrasound

18.1 Defect Orientation

- Angle beam probes can help detect inconveniently aligned defects
- Uses refraction. Can use multiple reflections too.

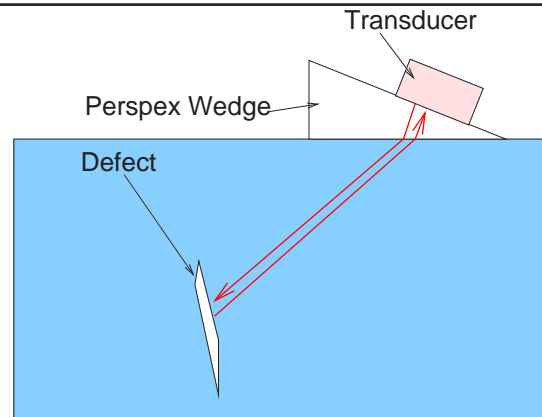

19 Ultrasound

19.1 Couplant

- Getting sound waves from transducer into specimen, and back from specimen into transducer is problematic
- Specimen needs to be smooth surfaced
 - Couplant (e.g. vaseline) is used which fills in the tiny imperfections which are still present
- Immersion tests can be used for less smooth parts
 - Specimen and transducer(s) are placed in a water bath. Water is couplant between transducers and specimen.

20 Ultrasound

20.1 Defect Sizing

- If defect is larger than sound beam, the outlines of the defect can be found and its size estimated quite well.
- Thickness of defect is harder to find.
- If the defect is smaller than the sound beam, it is possible to estimate the dimensions of the defect from the size of the reflection
 - Bigger reflecting area gives larger reflection .
 - Further distance from transducer gives smaller reflection.
 - Using both pieces of information, size can be estimated.

20.2 Link

Good outline: <http://www.geinspectiontechnologies.com/products/Ultrasonics/index.html>